

HIGH SECURITY AUTO PICK

NEW VERSION #3

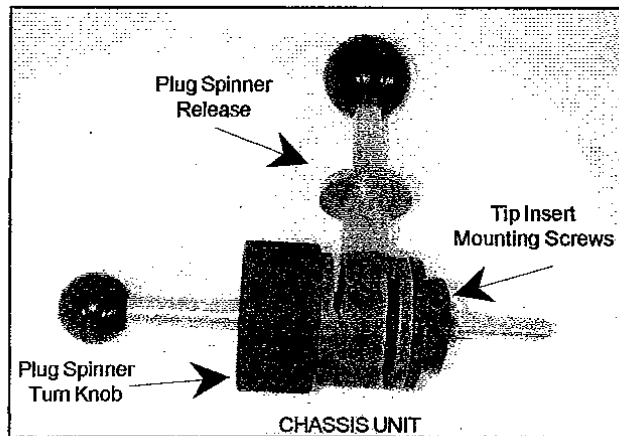

The following components are supplied:

- 1- Chassis Unit with New Built-In Plug Spinner
- 1- 1/16th Allen Wrench
- 1- Carry Case
- 1- Instructions

Comes with your choice of 1 of the following:

- 1- BMW 4 Track Guide Key & Guide Key Sleeve
- 1- BMW 2 Track Guide Key & Guide Key Sleeve
- 1- V.W. Guide Key & Guide Key Sleeve
- 1- M/B 2 Track Guide Key & Guide Key Sleeve

Please, DO NOT lubricate the lock you are picking!

HIGH SECURITY AUTO PICK

Components & Assembly

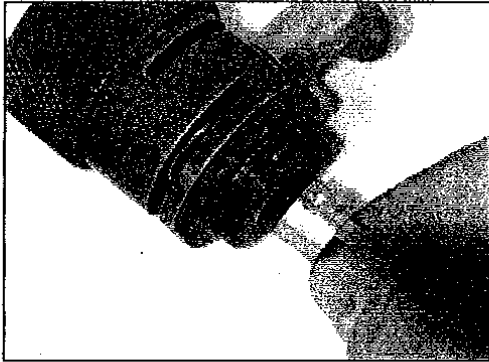

Before using the tool you will need to insert the matching plug tip into the chassis unit. Then secure the tip with the supplied Allen wrench. Do not over-tighten the set screws for the plug tip.

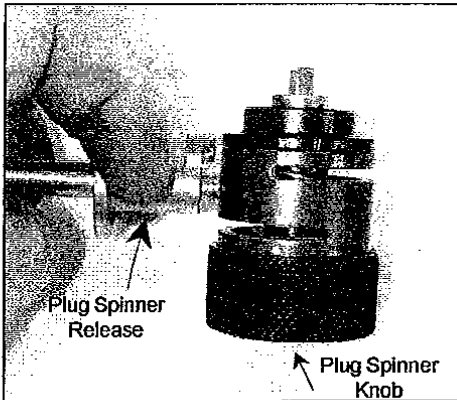

New Built-In Plug Spinner.

Some locks like the BMW must be picked to the locked position first and then you can use the new built-in plug spinner to spin the plug to the unlock position.

U.S. Models of the BMW driver's door locks need to be pick in the clockwise direction. Pull the plug spinner release and turn the knob to set the spinner for the counter-clockwise turning direction.

It may be necessary to lubricate the center of the chassis unit to help it spin faster.



BMW 2 & 4 Track:
Pick the lock Clockwise in the Drivers door.



BMW 2 & 4 Track:
Plug Spin Counter-Clockwise in the Drivers door to unlock.

HIGH SECURITY AUTO PICK

Components & Assembly



Audi - VW 2-Track: (U.S. Models)

The plug spinner is not needed because the driver's door lock cylinder can be picked to the directly to the unlock position.

Pick the lock Counter-Clockwise.

Special note about the keyway tip's.

- The BMW 4-Track tip enters the keyway until it stops.
- The BMW 2-Track tip enters the keyway to the first step on the tip.
(The BMW 2-Track & Audi-VW use the same keyway tip.)
- The Audi - VW 2-Track tip enters the keyway past the first step until it bottoms out. (The BMW 2-Track & Audi-VW use the same keyway tip.)

WARNING: Be careful when removing the keyway tip from the keyway, so you don't snag the face cap or shutter assembly.

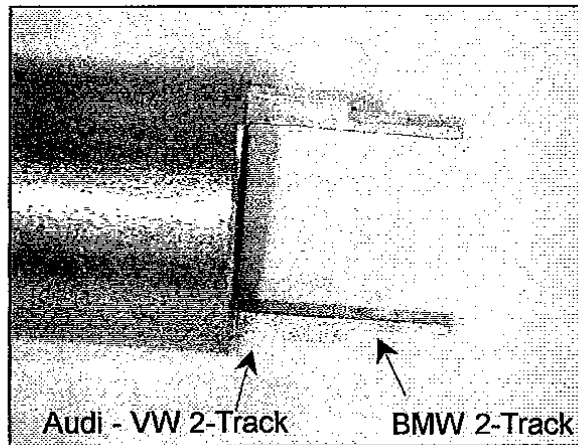

HIGH SECURITY AUTO PICK

General Use Example

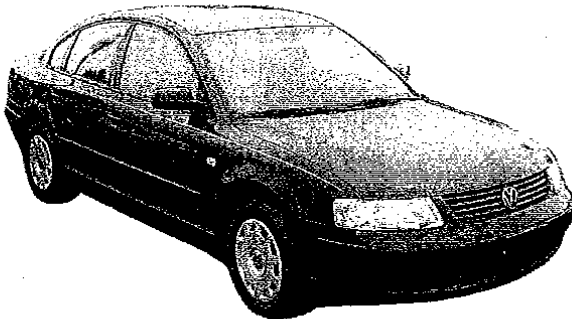

Before you start make sure you have installed the correct Guide Sleeve into the Chassis Unit.

The Audi-VW Guide Sleeve is the same one as the BMW 2-Track Pick Tool.

The tips on the Guide Sleeve are stepped. The first step is for the BMW 2-Track keyway. On the Audi-VW keyway the Guide Sleeve tips go all the way in the keyway (bottom out).

Insert the Chassis Unit into the keyway on the Drivers side door lock.

Insert the V.W. Guide into the keyway on the Drivers side door lock.

Do not lubricate the lock! The grease that is there from the factory helps slow the movement of the tumblers and helps the lock pick easier. On older models, like BMW, it may be necessary to inject lithium grease into the lock to aid in the picking process.

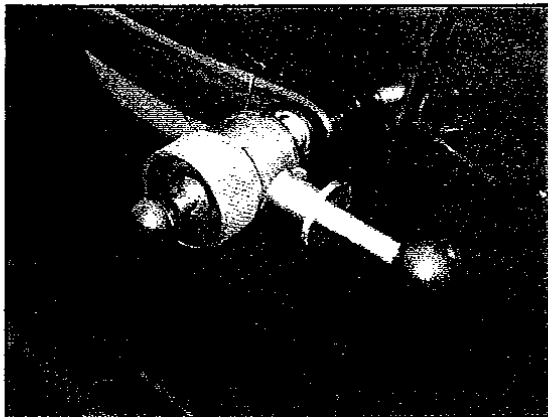
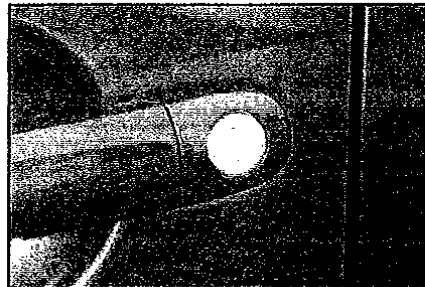

While maintaining light counterclockwise (unlock direction) turning pressure, remove the Key Guide.

Again, while maintaining light turning pressure, back off very slightly and then reapply light pressure (torque) to the unlock direction. Repeat this 2 or 3 times or until the lock turns to the unlock position, which is counterclockwise on the drivers door. You will be able to hear some tumblers drop when you do this. That is normal as they are moving in and out of the shear-line.

Repeat the procedure until the lock picks to the unlock position, remember on the VW's, light pressure (torque) is better. Do not over torque the tool or the keyway.